

# MICROFINISH GLOBE VALVES

## INSTALLATION OPERATION AND MAINTENANCE MANUAL



**MICROFINISH VALVES PVT. LTD.** 

Block no.23B, Plot no.1 to 6, Hubballi-Dharwad Bypass Road, Itigatti Village,  
Dharwad-580 114, Karnataka state, India. Phone: +91 836 2310015 / 16 / 19  
Email: sales@microfinishgroup.com Website: www.microfinishgroup.com

**THE AMERICAS**

**MICROFINISH VALVES, INC.** 

7505 Bluff Point Drive, Suite 100 Houston, Texas 77086, United States.  
Phone: +1 281-885-4250 / +1 281-885-4259 Fax: +1 281-866-0996  
Email: usasales@microfinishgroup.com Website: www.microfinishvalvesinc.com

## 1. INTRODUCTION

Microfinish Globe Valves have been designed and manufactured to give you long, excellent and trouble free service.

This manual provides you with all the relevant information to install operate and maintain the valve for long trouble free life.

Users and maintenance personnel should carefully read these instructions before installing, operating or performing maintenance work.

**Please note that all the drawings provided in this manual are of typical views.**



**To avoid damage or injury to personnel or equipment, always heed all warnings and instructions. Unprofessional re-conditioning, the use of foreign replacement parts or the performance of other maintenance steps than those described here, may cause a loss of efficiency or lead to personnel injury or damage to parts, and render the warranty void**

## 2. PRIOR TO INSTALLATION

- 2.1 On receipt of material check for any damage during transportation.
- 2.2 Each delivery includes a packing slip. When unpacking, check all delivered valves and accessories using this packing slip.
- 2.3 Report transport damage to the carrier immediately.
- 2.4 In case of discrepancies, contact sales office.
- 2.5 Wrapping and protection applied should be left in place until the valve is installed.
- 2.6 If the valves are left exposed, they should be protected against entry of foreign material in the valve parts.
- 2.7 Flush the pipe clean before mounting the valve in the pipeline. Impurities such as sand and parts of welding electrodes could damage internal parts of the valve.
- 2.8 If the valves are stored for a long time, they should be cleaned, lubricated and tested prior to installation.
- 2.9 It is advisable to store the valve in below cases;
  - 2.9.1 In case of Globe Valve, with metal to metal seat valve should be fully closed during storage / shipment.
  - 2.9.2 In case of Globe Valve with soft seat, ensure that seat is not over compressed.
- 2.10 Expansion or contraction of line should be accommodated by U expansion bend or expansion joint, so as to avoid the excessive stresses on the valve.
- 2.11 If the valve is tested by hydrostatically then the valve should be thoroughly cleaned and dried prior to being put into service.

### 3. INSTALLATION

- 3.1 The valve may be installed in any position, however avoid stem position downwards. It is recommended to mount the valve having stem in horizontal position.
- 3.2 If possible, install the valve in an upright position (actuator on top), to ease maintenance. An upright installation position is important with low-temperature applications, in order to keep the distance between the packing material and the medium as large as possible. The packing material then retains the ambient temperature as much as possible.



**Important: Do not insulate extension bonnets that are provided for hot or cold services**

- 3.3 After installing, check direction of flow again. The direction of flow is shown by the arrow on the housing.
- 3.4 Open and close the valve, and observe the movement of the actuator stem. The movement must be smooth and linear.
- 3.5 The packing gland nut must always be tightened slightly more than finger-tight.



**IMPORTANT: An excessively tightened gland nut can cause excessive packing wear and can hinder the free movement of the plug stem.**

- 3.6 Before using wrench all bolts should be tighten by fingers, after this wrench is used to take 3 to 4 turns on bolts and all bolts should be tighten equally.
- 3.7 Normally these valves are installed with pressure under the disc except for high temperature service. These may be installed with pressure above the disc.
- 3.8 The valve can be supported on its body with pipe clamps and supports. Do not fasten supporting structures to flange bolts which are shown in figure no.2.
- 3.9 While lifting, place the hoisting cable around the valve body as shown in figure no.1

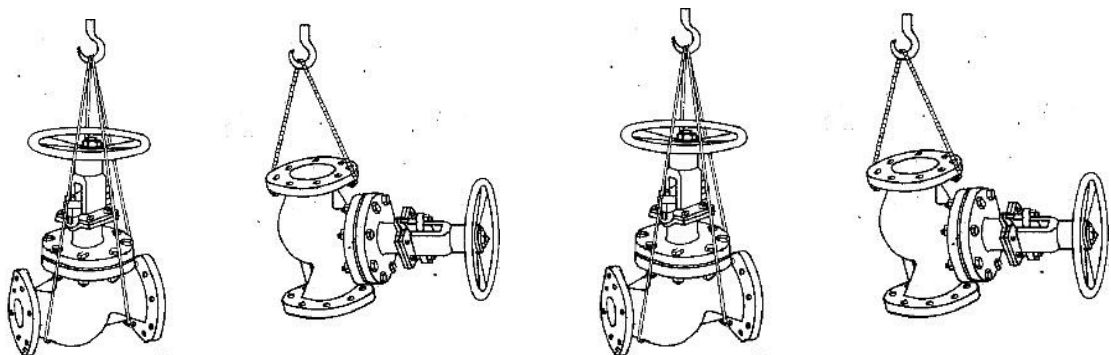

**Fig.1 Ways of hosting the valves**

- 3.10 Do not attempt to correct pipe misalignment by means of flange bolts.

- 3.11 Do not allow the valves to carry the weight of pipeline to avoid distortion and jamming.
- 3.12 Gland should be tightening uniformly to avoid leak in stem packing which arises after long storing time.
- 3.13 After using at fluctuating temperatures, re-tighten all bolt connections and check for leaks.
- 3.14 Use gasket suitable for the operating conditions. i.e. high temperature compressed asbestos.
- 3.15 A qualified welder must perform all welding operations & welding procedure shall be in accordance with ASME Boiler & Pressure Vessel Code Section IX.
- 3.16 When mounting the screwed end, butt weld end, socket weld end and flanged end type valves the following respective procedures must be followed, for better performance.
- 3.17 If slings are used, attach them so that the outer tubing or attaching parts are not damaged.



**Important: If slings are used, be aware that the center of gravity of the valve may be above the lifting point. In this case, secure or support the valve against rotating, to prevent damage or personnel injury.**

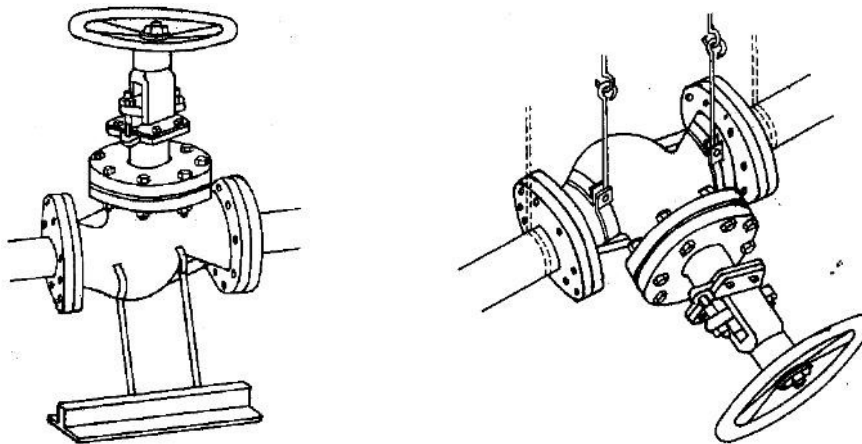

**Fig 2. Ways to supporting the valve**

### **3.18 SCREWED END VALVE INSTALLATION**

- 3.18.1 Clean both the mating parts before assembly.
- 3.18.2 Sealant if necessary should be applied only to the pipe or male threads.
- 3.18.3 Use correct size wrenches with flat jaws on hexagon or octagon ends.
- 3.18.4 Do not use undersized threads on section of pipe where the valves are to be installed.

### **3.19 BUTT WELD END VALVE INSTALLATION**

- 3.19.1 Keep the valve in 'Full Open' position.
- 3.19.2 Space the joint apart, co-axially with a 2 to 3 mm gap.
- 3.19.3 Use an internal welding backing ring where practical.
- 3.19.4 After finishing the welding operation clean the pipeline and valve parts by flushing or pigging to remove the impurities formed during welding.
- 3.19.5 Do not allow rapid application of excess welding material.
- 3.19.6 Do not allow the temperature of valve body seat area to exceed 120° C (248°F) to prevent seat and seal damage.
- 3.19.7 When butt weld end valves are purchased with no extended nipple, before welding, remove the central body assembly along with ball and seats, place a spacer of same dimensions and then weld the ends.

### **3.20 SOCKET WELD END VALVE INSTALLATION**

- 3.20.1 Keep the valve in 'Full Open' position.
- 3.20.2 First insert the pipe to full depth of socket then pull out about 1.5mm and weld.
- 3.20.3 Provide adequate support to the pipe on each side or to the valve prior to welding.
- 3.20.4 Weld each end of the valve with a continuous bead. The welding rod should not exceed 3.2 mm diameter.
- 3.20.5 Remove the spacer and reassemble the valve body assembly when the system cools down to ambient temperature.
- 3.20.6 Do not allow the temperature of valve body seat area to exceed 120° C (248° F) to prevent seat and seal damage.

### **3.21 FLANGED END VALVE INSTALLATION**

- 3.21.1 Be sure that flange gaskets and fasteners are suitable for the operating conditions.
- 3.21.2 Insert the valve (fully open position) along with suitable gasket between the mating flanges, align the flange bolt holes & hold it in place.
- 3.21.3 Hold the nuts first on backside of the valve flange and then insert the bolts.
- 3.21.4 Tighten all the bolts to finger tight.
- 3.21.5 Use two spanners to tighten the joint, in the sequence as shown in Figure 1.
- 3.21.6 To avoid leak in stem packing tightening should be done uniformly before installing the valve.
- 3.21.7 Flush the pipe line carefully once more when the valves mounted to remove all the possible impurities. Before flushing keep the valve open fully.
- 3.21.8 Re-tighten the packing if necessary until all leakage has stopped.

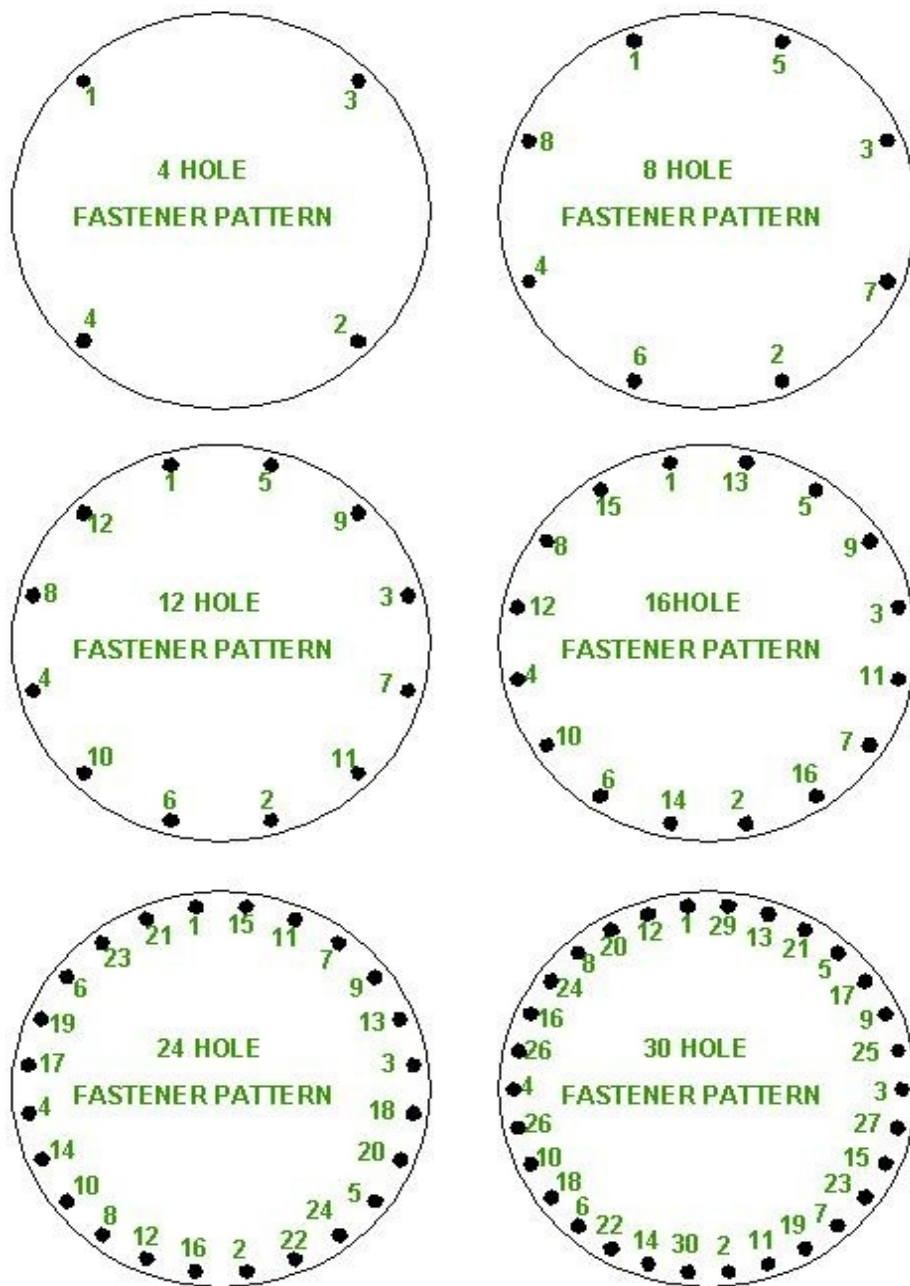

Fig 2. Bolting sequence chart

**Table : 01 Tightening Torques for fasteners**

<b>STUD / NUT SIZE</b>	<b>TIGHTENING TORQUE (Nm)</b>	
<b>M 6</b>	<b>11</b>	<b>14</b>
<b>M 8</b>	<b>25</b>	<b>30</b>
<b>M10</b>	<b>30</b>	<b>40</b>
<b>M 12</b>	<b>35</b>	<b>45</b>
<b>M 14</b>	<b>55</b>	<b>70</b>
<b>M 16</b>	<b>85</b>	<b>105</b>
<b>M 20</b>	<b>170</b>	<b>210</b>
<b>M 24</b>	<b>290</b>	<b>340</b>
<b>M 27</b>	<b>425</b>	<b>500</b>
<b>M 30</b>	<b>570</b>	<b>670</b>
<b>M 33</b>	<b>800</b>	<b>935</b>
<b>M 36</b>	<b>1000</b>	<b>1250</b>
<b>M 42</b>	<b>1350</b>	<b>1600</b>
<b>M 46</b>	<b>1700</b>	<b>1950</b>
<b>M 48</b>	<b>1785</b>	<b>2045</b>
<b>M 50</b>	<b>2200</b>	<b>2450</b>
<b>M 56</b>	<b>2800</b>	<b>3200</b>

#### **4. OPERATION AND MAINTENANCE**

Inspect valves for correct functioning at regular intervals (at least once every 6 months) as follows. This check can be made when installed and in many cases without interrupting production.

- 4.1** Examine gaskets for leaks and if necessary re-tighten bolts.
- 4.2** Check valve for damage caused by corrosive residues or corrosive vapors
- 4.3** Check packing bolts for correct tightening. Gland nuts on packing may only be tightened slightly more than finger-tight, or only tight enough to ensure a proper seal.

- 4.4 If the valves do not hold tight, don't use extra leverage on the hand wheel. Instead take the valve apart and inspect to locate the trouble.
- 4.5 Impacts and sudden jerks on the seat should be avoided as per as possible.
- 4.6 Valves should be opened and closed slowly to avoid hammering effect on the valve and pipeline.
- 4.7 If a through leak occurs, ensure that the valve is fully closed. Don't use extra leverage or extra force on the stem to prevent leakage. If leakage persists, replacement of seats is necessary.
- 4.8 After a long service life, when through valve leakage is observed, the seats can be interchanged.
- 4.9 If seat is not holding tight then close the supply and make sure that there is no service fluid in the line. Take out bonnet loosen the disc nut and take off the disc. Repair the surface seat ring can also be replaced.
- 4.10 While repairing or replacing the disc-plug assembly, it is advisable to remove the valve repair, test and then install
- 4.11 Never attempt to repair leaks on valve or pipe by welding, until all service fluid has been removed from the system.

## 5. DISASSEMBLY



**IMPORTANT: Keep hands, hair, clothing, etc. away from all moving parts. Failure to do so can lead to serious injury.**

For your safety and protection, it is important that the following precautions be taken prior to removing the valve from service or before any disassembly of the valve.

### 5.1 DISASSEMBLY FROM PIPE LINE

- 5.1.1 Keep hands out, since remotely actuated valves could close at any time. Disconnect all auxiliary piping of jackets and pneumatic or electric connections.
- 5.1.2 Wear any protective clothing or equipment normally required when working with media involved.
- 5.1.3 De-pressurize all the lines and drain the system fluid. Cycle the valve several times to relieve any pressure still inside the valve.
- 5.1.4 Keep the valve in full open position. Remove the valve and place it on a level surface in vertical position.

**WARNING!**

**VALVES SHALL NOT BE DISMANTLED IN CLOSED POSITION**

**5.2 DISASSEMBLY OF THE VALVE**

- 5.2.1 Ensure all service fluid has been removed from the system.
- 5.2.2 Remove the pipe flange bolts and nuts holding the valve firmly, then take out the valve from the line.
- 5.2.3 Remove hand wheel nut take off the hand wheel.
- 5.2.4 Remove indicator and yoke bolts and take off yoke and spindle nut.
- 5.2.5 Remove the bonnet nuts and take off the bonnet assembly.
- 5.2.6 Place the disassembled parts on clean wooden or cardboard surface. Do not keep parts on cement or metal surfaces to avoid damage.
- 5.2.7 Remove Back seal and packing. Seat Ring can also be dismantled.
- 5.2.8 Clean all parts carefully. If necessary use suitable solvent.
- 5.2.9 Check all the sealing surfaces and parts for damage or uneven wear. Minor scratches or flashes on the sealing surface can be removed using a fine abrasive cloth.

**6. ASSEMBLY**

Using the parts contained in complete repair kit, reverse the disassembly procedure.



**NEVER REUSE PACKING, BODY SEALS, STEM SEAL AND STEM WASHER.**

In case of damage / wear / corrosion to the parts of the valve, they need to be replaced during re-assembly.

## 7. GENERAL ASSEMBLY DRAWING

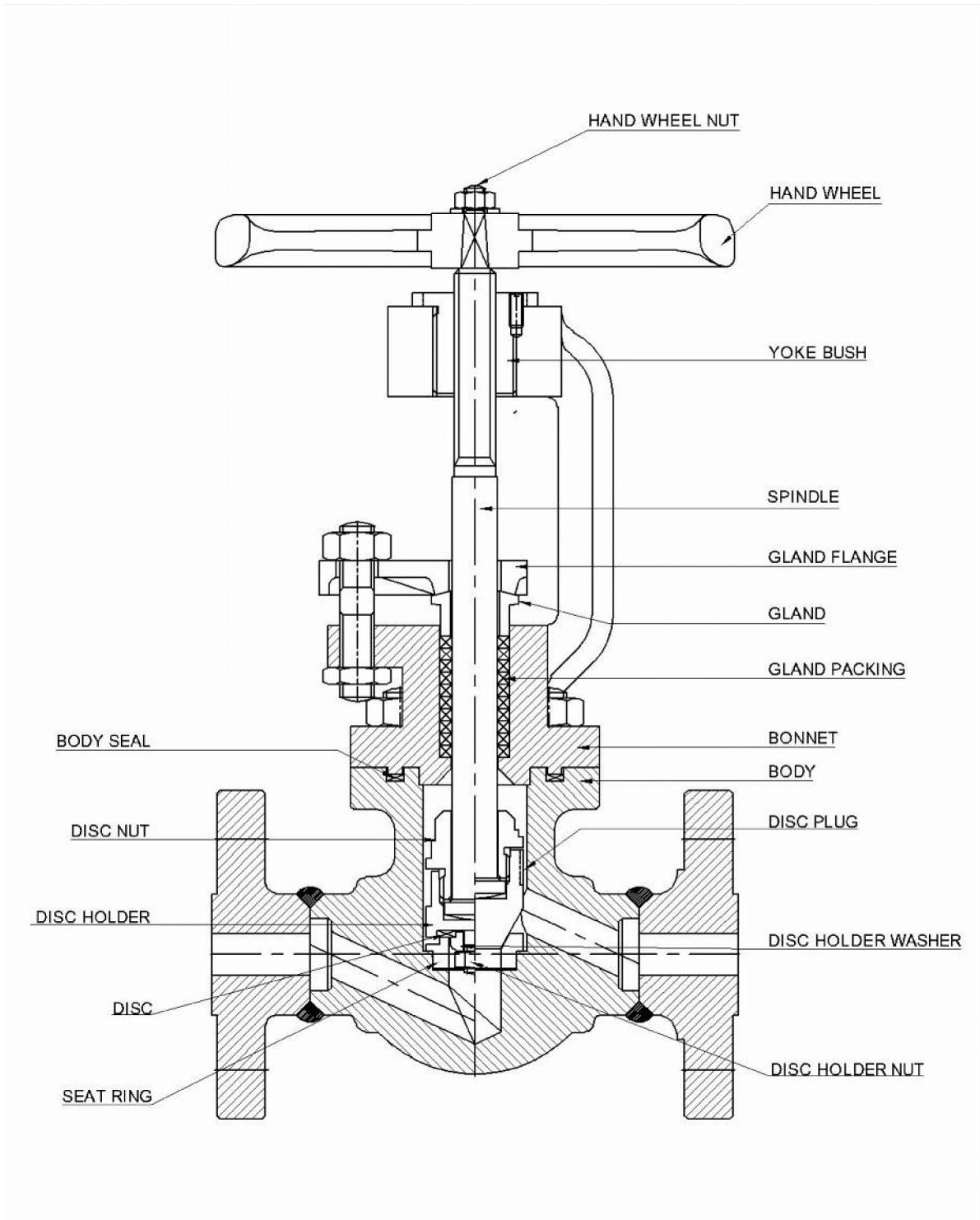

## 8. TROUBLE - SHOOTING CHART

<b>Fault</b>	<b>Possible cause</b>	<b>Remedy</b>
Stem motion impeded	<ol style="list-style-type: none"> <li>1. Packing excessively tightened</li> <li>2. Actuator has failed</li> <li>3. Shaft key sheared</li> </ol>	<ol style="list-style-type: none"> <li>1. Tighten gland nut slightly more than "finger-tight"</li> <li>2. Replace or repair actuator</li> <li>3. Determine cause of shearing and correct, replace shaft key</li> </ol>
Shaft Packing Leakage	<ol style="list-style-type: none"> <li>1. Gland bushing binding</li> <li>2. Packing rings damaged</li> <li>3. Packing worn out</li> </ol>	<ol style="list-style-type: none"> <li>1. Loosen gland nuts and readjust bushing</li> <li>2. Depressurize valve and replace packing rings</li> <li>3. Depressurize valve and replace packing rings</li> </ol>
Through Valve Leakage	<ol style="list-style-type: none"> <li>1. Gaskets damaged</li> <li>2. Inadequate actuator thrust</li> <li>3. Incorrect direction flow</li> <li>4. Hand wheel, incorrectly adjusted (acts like end stop)</li> </ol>	<ol style="list-style-type: none"> <li>1. Replace gaskets</li> <li>2. Check air feed. If air feed is ok, contact sales office.</li> <li>3. Check specification . contact sales office</li> <li>4. Adjust hand wheel</li> </ol>
Inadequate flow	<ol style="list-style-type: none"> <li>1. Operating requirements too high</li> </ol>	<ol style="list-style-type: none"> <li>1. Check operating data. Contact sales office</li> </ol>
Plug slams	<ol style="list-style-type: none"> <li>1. Inadequate supply pressure</li> </ol>	<ol style="list-style-type: none"> <li>1. Check supply pressure, seal leaks, remove blockages</li> </ol>

## 9. RECOMMENDED LUBRICATION

<b>Part</b>	<b>Lubrication</b>	<b>Application</b>	<b>Frequency</b>
Stem threads	Castrol MP	Directly to threads	When threads appear dry
Yoke nut	Castrol MP	Inject through grease fitting at hub of yoke	Concurrently with stem thread lubrication